

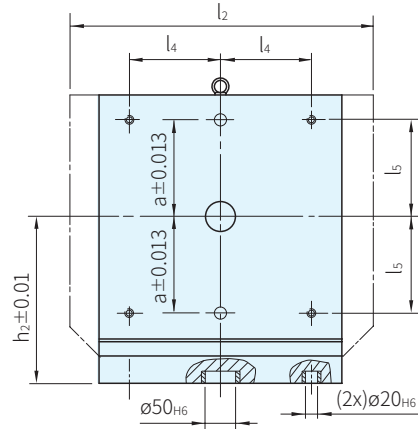

|    |    |
|----|----|
| 材質 | 處理 |
| 鑄鋼 | 燒鈍 |

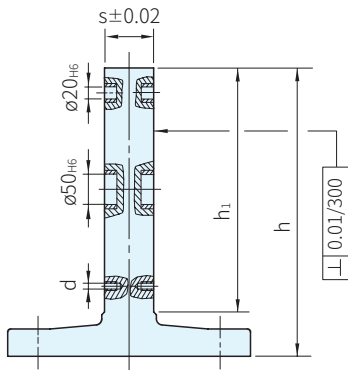
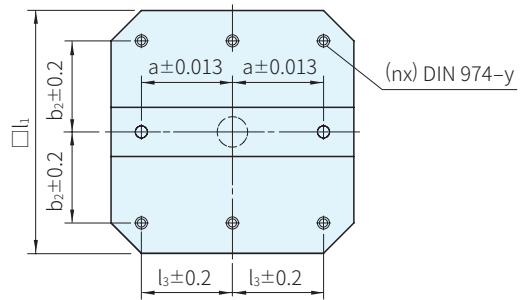

| 品號       | l <sub>1</sub> | l <sub>2</sub> | h <sub>1</sub> | h   | a   | b <sub>2</sub> | l <sub>3</sub> | l <sub>4</sub> | l <sub>5</sub> | h <sub>2</sub> | s   | d   | y  | 螺絲用 | 固定孔數量<br>N | 質量<br>kg | 庫存 |
|----------|----------------|----------------|----------------|-----|-----|----------------|----------------|----------------|----------------|----------------|-----|-----|----|-----|------------|----------|----|
| 1906.240 | 400            | -              | 400            | 475 | 150 | 150            | 150            | 100            | 100            | 275            | 80  | M12 | 12 | M12 | 4          | 147      | △  |
| 1906.340 | 400            | 500            | 400            | 475 | 150 | 150            | 150            | 200            | 100            | 275            | 80  | M12 | 12 | M12 | 4          | 168      | △  |
| 1906.440 | 500            | -              | 500            | 595 | 200 | 200            | 200            | 200            | 200            | 345            | 100 | M12 | 12 | M12 | 6          | 295      | △  |
| 1906.540 | 500            | 630            | 500            | 595 | 200 | 200            | 200            | 200            | 200            | 345            | 100 | M12 | 12 | M12 | 6          | 326      | △  |
| 1906.640 | 630            | -              | 630            | 725 | 200 | 200            | 200            | 200            | 200            | 410            | 130 | M16 | 16 | M12 | 6          | 445      | △  |

訂貨：  交期：

1906.240